

REV: 032412



PRODUCT FEATURES:

- Hot-Swap / Redundant Rectifier Module
- Full Featured Status & Control Signals
- Single Phase Input with Active PFC
- Front Panel LED Indicators



INPUT SPECIFICATIONS:

VOLTAGE	1Ø 220 VAC ±20%
FREQUENCY	47-63Hz
INRUSH	50A @ 230VAC Input Range (Max Cold Start)
CURRENT	5A @ 230 VAC (Max. Continuous)
PROTECTION	Single 10A Fuse / 250 VAC
LEAKAGE	3mA Max @ 264 VAC
EFFICIENCY	> 87% (typical)
HARMONICS	EN61000-3-2 Class D Compliant (>95 PF)

OUTPUT SPECIFICATIONS:

OUTPUT	27V DC / 25 Amps
ADJUSTMENT RANGE	26VDC to 28.5VDC
MINIMUM LOAD	7.5A
LINE REGULATION	±1% Max over entire input range
LOAD REGULATION	±1% maximum
RIPPLE	100mV pk-k max, (20MHz)
SETPOINT ACCURACY	±.1%
EXCURSION	±3% Max for 50% Step Load
RECOVERY	500us max
OVER CURRENT	105-130% (Auto-Recovery)
OVER VOLTAGE PROTECTION	29V ± .5V (recycle input to reset)

STATUS & CONTROL SPECIFICATIONS:

ON/OFF SWITCH	Pressed in turns module on
ON LED	Green indicates DC on & within specification
STBY LED	Yellow indicates AC applied & On/Off Switch OFF
FAIL	Red indicates module failure

GENERAL SPECIFICATIONS:

OPERATING TEMPERATURE	-30 ~ +50°C
STORAGE TEMPERATURE	-40 ~ +85°C
COOLING	Internal fans
HUMIDITY	5-95% (non-condensing)
VIBRATION	10-55Hz, 2G, 3Min Period, / 60 min each (3 axes)
SHOCK	20G Peak Acceleration
RELIABILITY	>150K hours per Mil-Spec 217
AUDIBLE NOISE	< 65 dBA
SIZE	65 x 331 x 5.11mm / 2.59" x 13.03" x 5.11"

EMISSIONS:

EMISSIONS	CISPR Class A (Conducted)
ELECTROSTATIC DISCHARGE	EN61000-4-2, 4kV Contact / 8kV Air
RADIATED SUSCEPTIBILITY	EN61000-4-3, 26-1000MHz, 10V/M, 80%AM
EFT / BURSTS	EN61000-4-4, 2kV
SURGES	EN61000-4-5, 2kV Earth, 1kV Line-Line
CONDUCTED IMMUNITY	EN61000-4-6, 0.15-800MHz, 10V 80%
VOLTAGE DIPS	EN61000-4-10, 95% Dip & 10ms, 30% Dip & 500ms
VOLTAGE INTERRUPTIONS	EN61000-4-11, 95% reduction, 5ms
FLUCTUATIONS & FLICKER	EN61000-3-3



OUTLINE DRAWING:

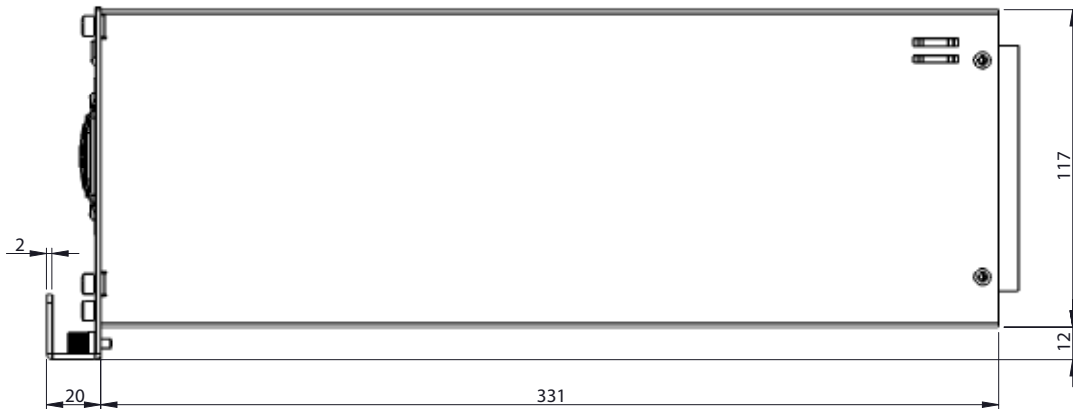
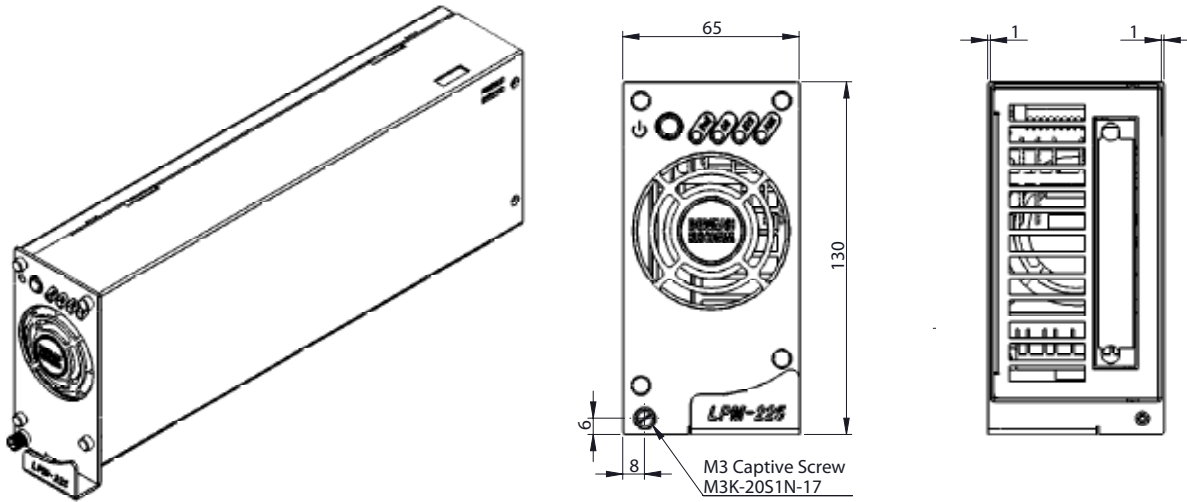

HOT-SWAP / REDUNDANT RECTIFIER MODULE

